

## SEV<sub>412</sub>

SUBMERSIBLE NON-CLOG PUMP

*Barnes SEV pumps combine high quality, high performance and low cost in a rugged, heavy duty design. Capable of handling up to 2 inch spherical solids, the pump utilizes a vortex impeller and a combination of cast iron and stainless steel components to stand up to the toughest residential sewage ejector applications.*

### **Outstanding Performance**

- Maximum flow rate to 72gpm at 11' of head
- Maximum shutoff head of 25'
- Vortex impeller provides 2" solids handling capability
- Permanent split capacitor motor for reliable, high performance, longer motor life, greater starting torque, and lower amp draw
- 1/2hp 3450rpm single phase motor includes overload protection
- Heavy duty upper and lower ball bearings are oil lubricated for superior cooling and maximum life

### **Heavy Duty Materials of Construction**

- Cast iron motor housing
- Cast iron pump body
- Cast iron multi-vane vortex impeller
- Stainless steel pump shaft
- Stainless steel hardware
- Buna-N O-rings

### **Level Control Options**

- Manual operation, no control provided
- Wide angle mechanical float mounted on discharge pipe or pump body
- Snap action vertical float switch mounted on discharge pipe or pump body
- All switches utilize "piggy back" switches which eliminates the need to pull pump to check for switch failure.



### Additional Pump Features

- CSA C/US listed
- 20' cord length standard
- 12 month limited warranty

### Available Models

- SEV412  
manual unit, no control provided
- SEV412A  
furnished with mechanical float for pipe mount
- SEV412VF  
furnished with vertical float for pipe mount
- SEV412AT  
furnished with mechanical float tethered to pump
- SEV412VFT  
furnished with vertical float mounted to pump

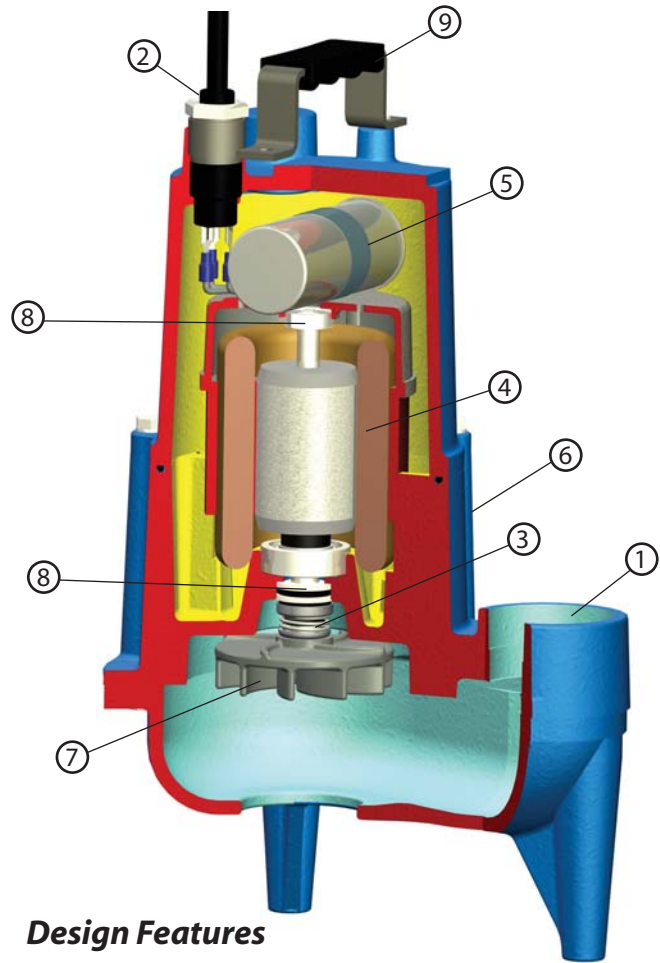
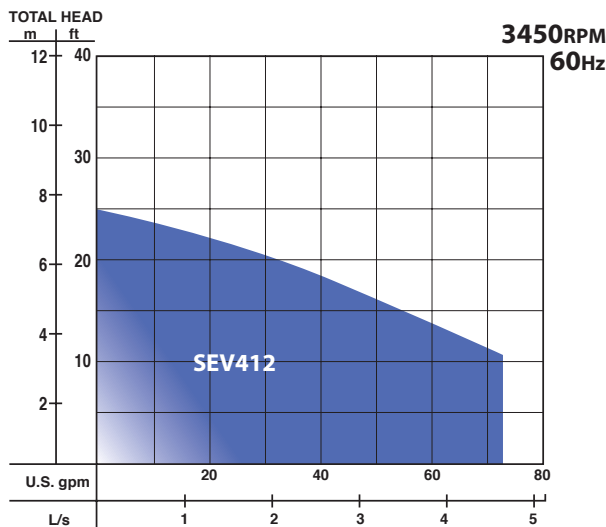

### Design Features

1. 2" NPT outlet connection
2. Proven cord entry design prevents leakage
3. Heavy duty industrial Type 21 silicon carbide seal
4. 1/2 HP motor for efficient and reliable effluent pumping
5. Motor capacitor provides high start torque
6. Corrosion-resistant cast iron construction
7. Vortex impeller and generous casing volute easily pass up to 2 inch solids.
8. Oil-lubricated ball bearings provide maximum life
9. Stainless steel lifting handle with rubber grip

**CRANE**<sup>®</sup>

A Crane Co. Company

PUMPS & SYSTEMS

[www.cranepumps.com](http://www.cranepumps.com)

#### Crane Pumps & Systems

420 Third Street  
Piqua, Ohio 45356  
(937) 778-8947  
Fax (937) 773-7157

#### Crane Pumps & Systems Canada

83 West Drive  
Brampton, Ont. Canada L6T 2J6  
(905) 457-6223  
Fax (905) 457-2650

© Crane Pumps & Systems, Inc.  
A Crane Co. Company  
Printed in U.S.A.  
BPPSEV - Rev. B (10/08)